

THIS DRAWING IS UNPUBLISHED. RELEASED FOR PUBLICATION, 19 .
 © COPYRIGHT 19 BY AMP INCORPORATED. ALL INTERNATIONAL RIGHTS RESERVED.

LOC	DIST	P	F	ZONE	LTR	DESCRIPTION	DATE	APPD
AF	50				J	REV PER 0L10-0284-97	6/25/97	JR/PD

1 CONTINUOUS STRIP ON REELS.

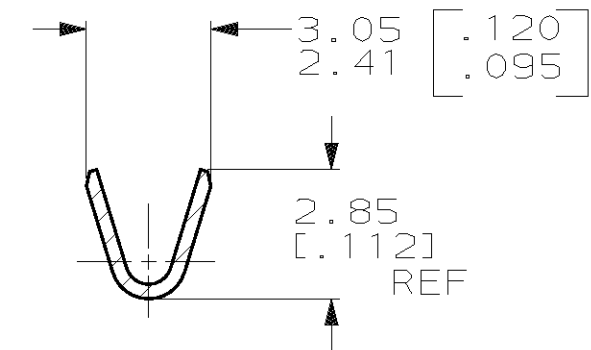
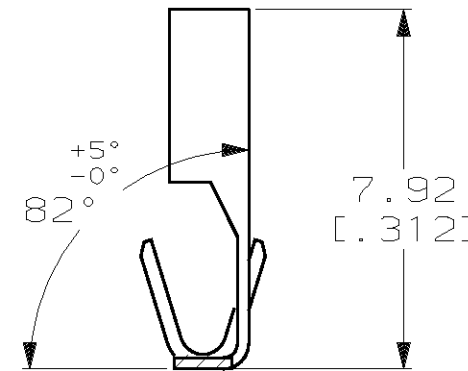
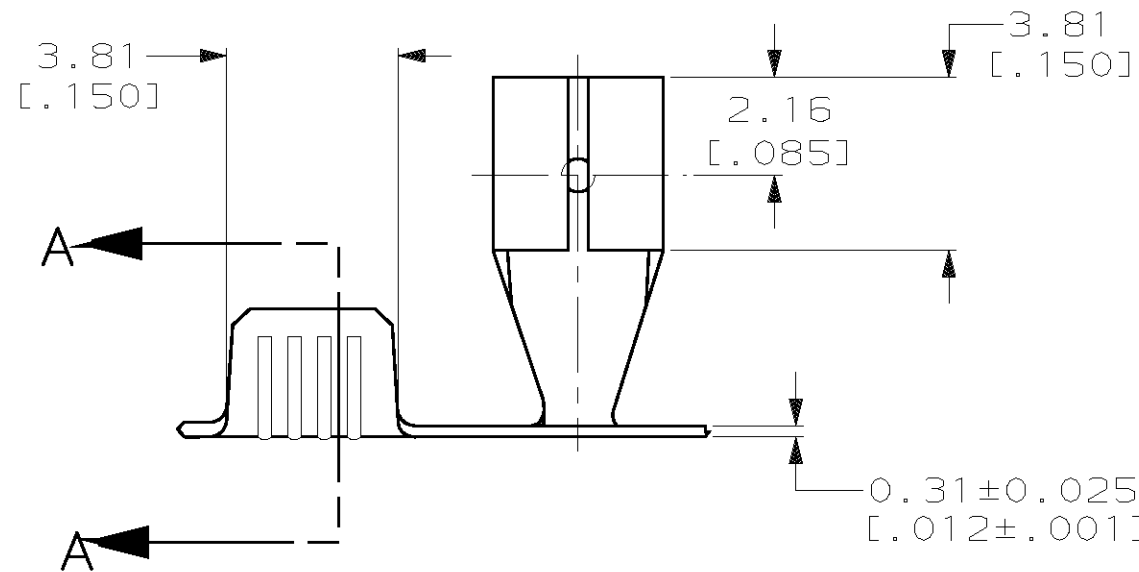
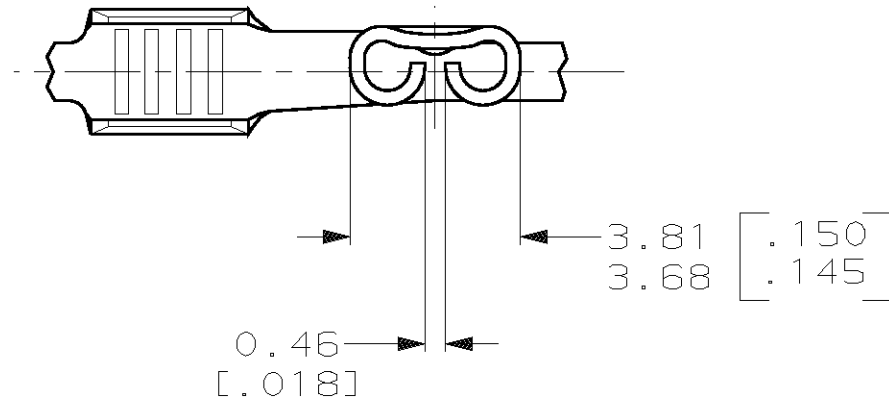

SECTION A-A

STRIP LENGTH	TYPE	WIDTH	HEIGHT	WIRE
4.77 [.188]	F	2.03 [.080]	1.52 [.060]	16
			1.32 [.052]	18
			1.19 [.047]	20
			1.11 [.044]	22
±0.38 [.015]			±0.051 [.002]	

WIRE BARREL CRIMP

THIS DRAWING IS A CONTROLLED DOCUMENT FOR AMP INCORPORATED. IT IS SUBJECT TO CHANGE AND THE CONTROLLING ENGINEERING ORGANIZATION SHOULD BE CONTACTED FOR THE LATEST REVISION.

[#22-#16] AWG	0.51±0.025 [.020±.001]	60991-1
WIRE SIZE	MATING TAB THICKNESS	PART NO
DR 4/3/95 JR RUTH	AMP AMP Incorporated Harrisburg, PA 17105-3608	
CHK 4/3/95 MS FEHER	NAME RECEPTACLE, FASTON, 2.79 [.110] SERIES	
APPD 4/3/95 P DESANTIS	SIZE	CAGE CODE
APPD 4/3/95 R REINER	B	00779
PRODUCT SPEC	DRAWING NO	
		C-60991
APPLICATION SPEC 114-2028	SCALE	SHEET
WEIGHT -	6:1	1 OF 1